

# INSTRUCTION SHEET

## OFF VEHICLE CARBURETOR SERVICE

### AISAN 2 BARREL

TOYOTA 22R ENGINE

**GENERAL EXPLODED VIEW**

THE GENERAL DESIGN AND PARTS SHOWN WILL VARY TO  
INDIVIDUAL UNITS COVERED ON THIS INSTRUCTION SHEET.

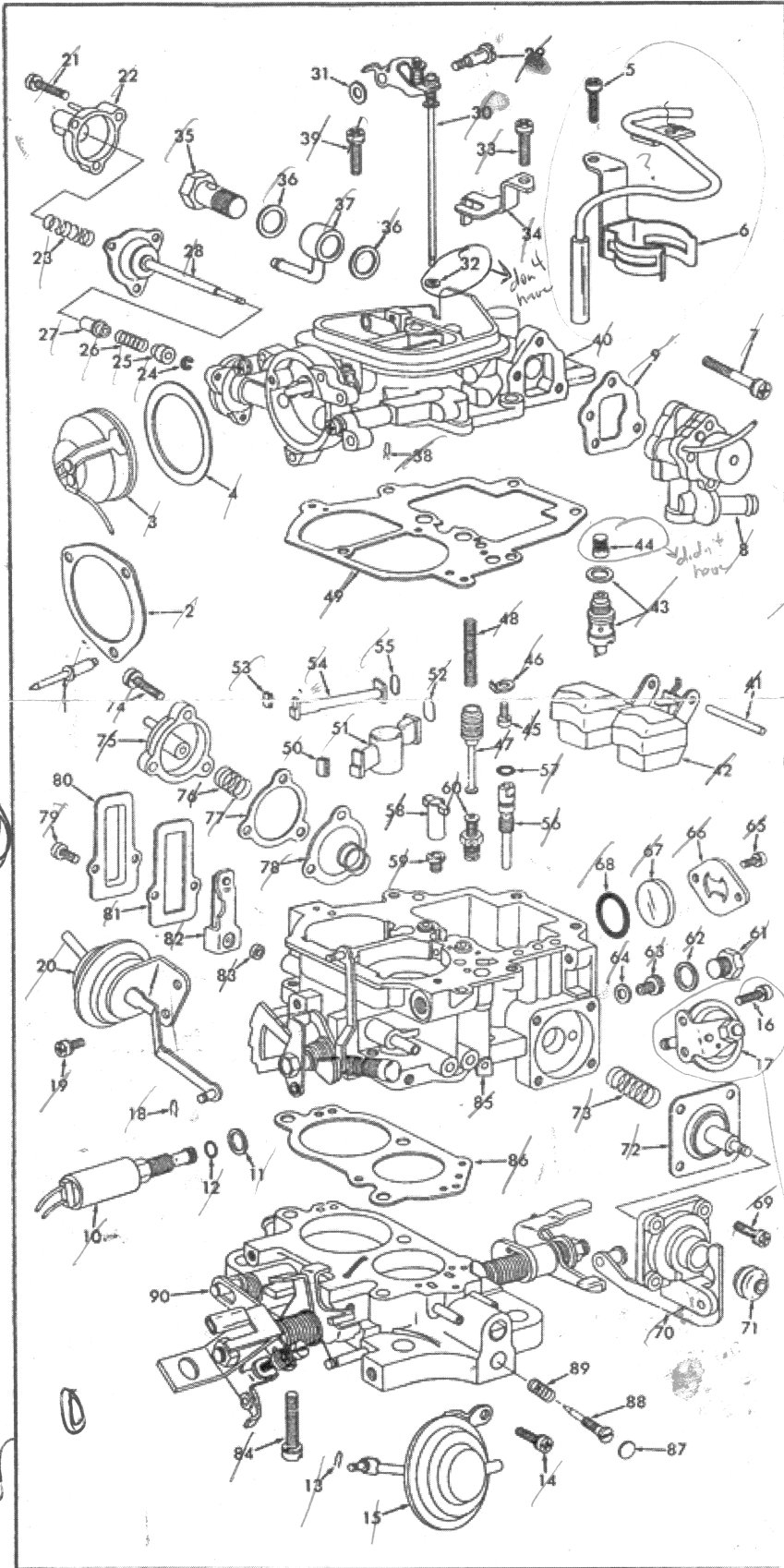

**DISASSEMBLY**

USE EXPLODED VIEW AS A GUIDE. THE NUMERICAL SEQUENCE MAY GENERALLY BE FOLLOWED TO DISASSEMBLE UNIT FAR ENOUGH TO PERMIT CLEANING AND INSPECTION. DRILL OR CUT OFF POP RIVET HEADS (1) TO REMOVE CHOKE COVER. TO REMOVE PLUGS COVERING SCREWS (21) AND IDLE NEEDLE (88) CENTER PUNCH CENTER OF PLUGS. CAREFULLY DRILL A HOLE IN PLUG. (NOTE THERE IS ONLY .040" CLEARANCE BETWEEN PLUG AND SCREWS OR NEEDLE.) USE A PULLER OR PRY PLUG FROM HOLE.

**NOMENCLATURE**

REF. NO.	REF. NO.
1. POP RIVET (3)-CHOKE RETAINER	44. SCREEN-FUEL INLET
2. RETAINER-CHOKE COVER	45. SCREW & LOCKWASHER-RETAINER
3. CHOKE COVER ASSY.-ELECTRIC	46. RETAINER-POWER PISTON
4. GASKET-CHOKE COVER	47. PISTON-POWER
5. SCREW & LOCKWASHER (2)-TUBE & BRACKET ASSY.	48. SPRING-POWER PISTON
6. TUBE & BRACKET ASSY.	49. GASKET-BOWL COVER
7. SCREW & LOCKWASHER (3)-BOWL VENT SOLENOID ASSY.	50. RETAINER-VENTURI
8. BOWL VENT SOLENOID ASSY.	51. O-RING-PRM VENTURI
9. GASKET-BOWL VENT SOLENOID ASSY.	52. RETAINER-VENTURI
10. SOLENOID ASSY.-IDLE SHUT OFF	53. O-RING-PRM VENTURI
11. GASKET-SOLENOID	54. VENTURI-SECONDARY
12. O-RING-SOLENOID	55. O-RING-SEC. VENTURI
13. RETAINER-THROTTLE POSITIONER STEM	56. JET-SLOW
14. SCREW & LOCKWASHER (2)-THROTTLE POSITIONER	57. O-RING-SLOW JET
15. THROTTLE POSITIONER ASSY.	58. GUIDE-METERING NEEDLE
16. SCREW & LOCKWASHER-DASHPOT	59. JET-SEC. MAIN
17. DASHPOT ASSY.	60. POWER VALVE & JET ASSY.
18. RETAINER-CHOKE OPENER STEM	61. PLUG-PRM MAIN JET
19. SCREW & LOCKWASHER (2)-CHOKE OPENER	62. GASKET-PLUG
20. CHOKE OPENER ASSY.	63. JET-PRM MAIN
21. SCREW & LOCKWASHER (3)-COVER	64. GASKET-PRM MAIN JET
22. COVER-CHOKE BREAKER	65. SCREW (2)-WINDOW RETAINER
23. SPRING-CHOKE BREAKER	66. RETAINER-WINDOW
24. E-CLIP-BUSHING DIAPHRAGM STEM	67. WINDOW-FUEL LEVEL
25. BUSHING-OUTER	68. O-RING-WINDOW
26. SPRING-DIAPHRAGM STEM	69. SCREW & LOCKWASHER (4)-PUMP COVER
27. BUSHING-INNER	70. COVER-PUMP
28. DIAPHRAGM ASSY.-CHOKE BREAKER	71. BOOT-PUMP STEM
29. SCREW-SEC. METERING NEEDLE ASSY.	72. DIAPHRAGM ASSY.-PUMP
30. SEC. METERING NEEDLE ASSY.	73. SPRING-PUMP DIAPHRAGM
31. WASHER-SCREW	74. SCREW & LOCKWASHER (3)-COVER
32. SEAL-METERING NEEDLE (PLASTIC)	75. COVER-AUX. PUMP
33. SCREW & LOCKWASHER-FUEL UNION BRACKET	76. SPRING-AUX. PUMP DIAPHRAGM
34. BRACKET-FUEL UNION	77. GASKET-DIAPHRAGM
35. BOLT-FUEL UNION	78. DIAPHRAGM ASSY. AUX. PUMP
36. GASKET (2)-FUEL UNION	79. SCREW & LOCKWASHER (2)-COVER
37. FUEL UNION	80. COVER-HOT IDLE COMPENSATOR VALVE
38. RETAINER-FAST IDLE LINK (RUBBER)	81. GASKET-COVER
39. SCREW & LOCKWASHER (2)-BOWL COVER	82. VALVE-IDLE COMPENSATOR
40. BOWL COVER ASSY.	83. SEAL-IDLE COMP. VALVE
41. PIN-FLOAT	84. SCREW & LOCKWASHER (3)-THROTTLE BODY
42. FLOAT & LEVER ASSY.	85. BOWL ASSY.
43. NEEDLE & SEAT ASSY.	86. GASKET-THROTTLE BODY
	87. PLUG-IDLE NEEDLE
	88. NEEDLE-IDLE ADJUSTING
	89. SPRING-IDLE ADJ. NEEDLE
	90. THROTTLE BODY ASSY.

**CLEANING**

CLEANING MUST BE DONE WITH CARBURETOR DISASSEMBLED. USE A CARBURETOR CLEANING SOLVENT. SOAK PARTS LONG ENOUGH TO SOFTEN AND REMOVE ALL FOREIGN MATERIAL. MAKE CERTAIN THE THROTTLE BORES ARE FREE OF ALL CARBON DEPOSITS. WASH OFF IN SUITABLE SOLVENT. BLOW OUT ALL PASSAGES IN CASTINGS WITH COMPRESSED AIR AND CHECK CAREFULLY TO INSURE THOROUGH CLEANING OF OBSCURE AREAS. CAUTION: DO NOT SOAK RUBBER PARTS, OR ITEMS SUCH AS (3), (8), (10), (15), (17), (20), (42), (82) IN CLEANING SOLVENTS.

**REASSEMBLY**

REASSEMBLE IN REVERSE ORDER OF DISASSEMBLY. NOTE SPECIAL INSTRUCTIONS AND ADJUSTMENTS.

**SPECIAL INSTRUCTIONS**

IDLE ADJUSTING NEEDLE (88)-TURN NEEDLE IN UNTIL LIGHTLY SEATED. THEN BACK OUT 2 1/2 TURNS.

*Handwritten notes:*

- only for carburetors throttle body gasket
- #33 screw for fuel union
- need venturi O-rings (primary & secondary)
- compressed air
- primary main jet
- auxiliary advance pump diaphragm gasket
- need
- don't have
- need one more
- need

# ADJUSTMENTS

① BOWL COVER INVERTED. (NO GASKET). FLOAT RESTING ON NEEDLE OF ITS OWN WEIGHT. MEASURE DISTANCE BETWEEN FLOAT AT TOE END AND CASTING SURFACE.

SETTING	
1981-82	10.5MM
1983-85	9.5MM
1986-88	8.8MM

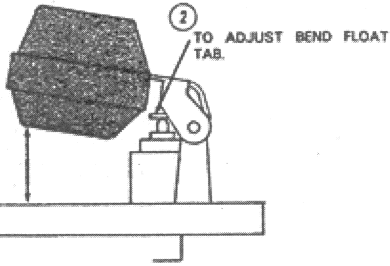

CAUTION: DO NOT EXERT PRESSURE ON RESILIENT NEEDLE VALVE.

DRY FLOAT LEVEL ADJUSTMENT

FIG. 1

① BOWL COVER INVERTED. RAISE FLOAT BY HAND UNTIL IT CONTACTS FLOAT HANGER. MEASURE DISTANCE FROM BOTTOM OF FLOAT TO CASTING SURFACE.

48 MM SETTING

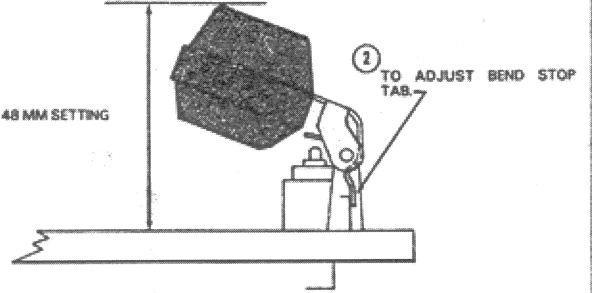

FLOAT DROP ADJUSTMENT

FIG. 2

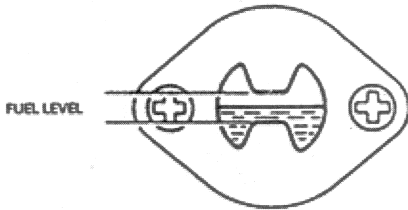

CHECK THAT THE WET FUEL LEVEL IS BETWEEN GAUGE LEGS. CORRECT IF NECESSARY.

WET FLOAT LEVEL

FIG. 3

REV. 12/86